

## Using your Flo arm

- 9 Once it has been correctly set up, your Flo arm permits you to easily position your monitor wherever you want it with fingertip control

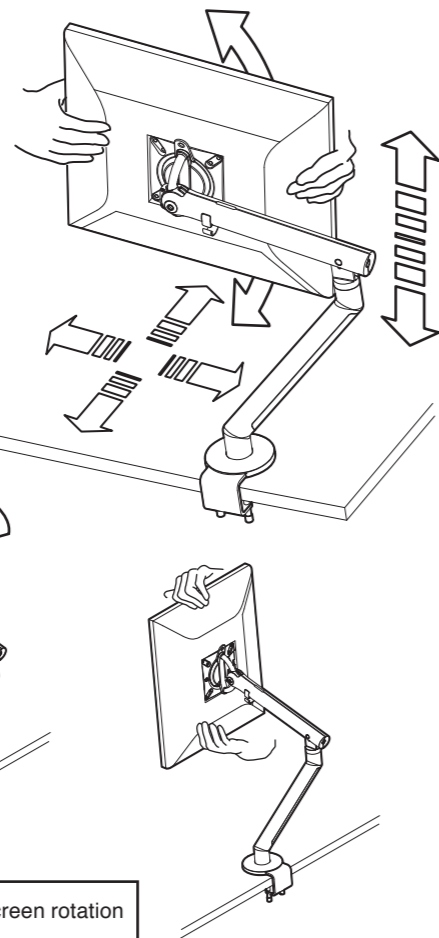

The monitor can easily be swivelled from landscape to portrait orientation

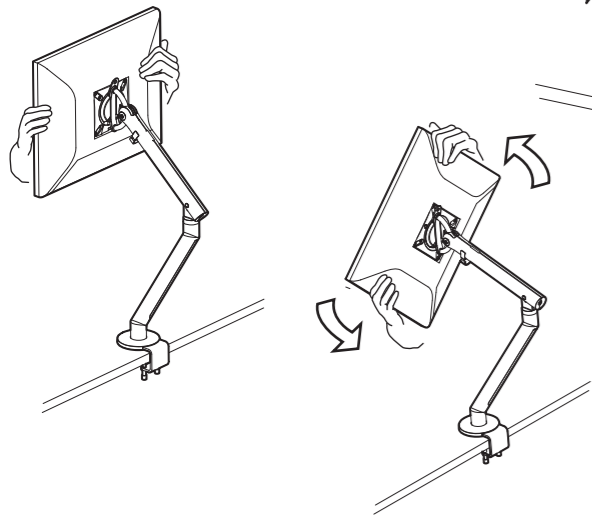

⚠ Ensure you have allowed enough free cable for screen rotation

## Reconfiguring the 180° stop function

- 10 The Flo clamp base is factory fitted with a 180° stop feature. You can permit 360° rotation by simply pulling the cover and base from the clamp and repositioning the stop feature as shown below.

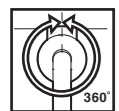
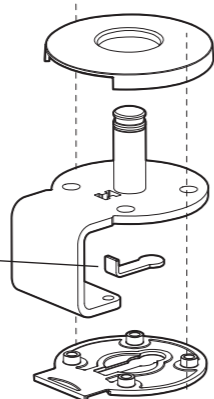

360° rotation configuration

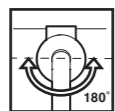

180° rotation configuration

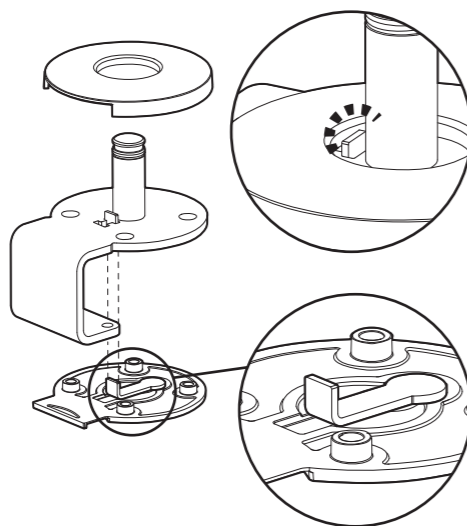
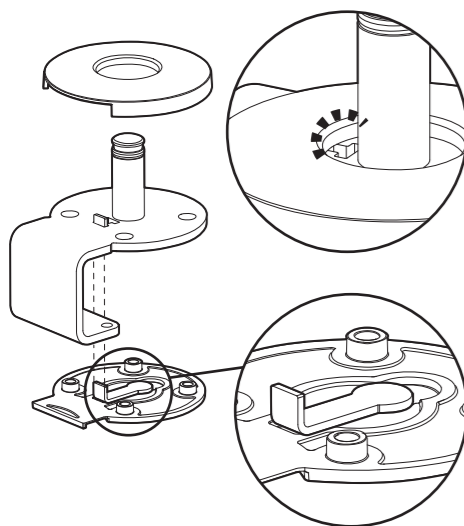

## ⚠ WARNUNG

Deutsch

- Sicherstellen, dass Schreibtisch / Arbeitsfläche / Wand / Trennwand das Gewicht von Arm(en) und Monitoren tragen kann
- Dieses Produkt nur für den Zweck verwenden, für den es konstruiert wurde
- Das getragene Gewicht darf 9kg pro Arm nicht überschreiten
- Den Monitor beim Einstellen gut festhalten
- Vorsicht: Nicht die Finger einklemmen
- Die Arm nicht auseinander nehmen oder umbauen
- Den Monitor erst dann befestigen, wenn die Arm montiert ist
- Schrauben für den Bildschirm NICHT mitgeliefert, bitte kontaktieren Sie Ihren Monitor-Lieferanten
- Schrauben für Wandbefestigung NICHT mitgeliefert
- Einige Monitore haben Aussparungen und erfordern möglicherweise Abstandshalter oder eine 75mm-VESA-Platte

## WARTUNG und INSPEKTION

- Sicherstellen, dass alle Schrauben festgezogen sind und, falls erforderlich, gelegentlich nachstellen. Mit einem feuchten Tuch säubern. KEINE Lösemittel

## ⚠ AVERTISSEMENT ET MISE EN GARDE

Français

- Le bureau, le plan de travail, le mur ou la cloison doit pouvoir supporter le poids du ou des bras et de l'écran.
- Ce produit ne doit pas servir à d'autres fins que celle prévue.
- Le poids de l'écran ne doit pas dépasser 9kg par bras.
- Tenir fermement l'écran pendant les réglages.
- Faire attention de ne pas se coincer les doigts.
- Ne pas démonter ou modifier les bras.
- Ne pas fixer l'écran avant d'avoir assemblé le bras.
- Les vis servant à fixer l'écran NE SONT PAS fournies. Contacter le fabricant de l'écran.
- Les vis pour le montage mural NE SONT PAS fournies.
- Pour certains écrans qui ont des renforcements, il faut parfois utiliser des cales d'espacement ou une plaque VESA de 75mm.

## ENTRETIEN et INSPECTION

- S'assurer que toutes les vis sont bien serrées et les resserrer au besoin. Nettoyer à l'aide d'un chiffon humide. PAS DE solvants.

## ⚠ ADVERTENCIA

Español

- Asegurarse de que el escritorio/la superficie de trabajo/la pared/el tabique sea adecuado para soportar el peso del o de los brazos y de los monitores
- No usar este producto para otro propósito que no sea aquél para el cual fue diseñado
- El peso soportado no debe exceder 9kg por brazo
- Sujetar el monitor firmemente cuando se realicen ajustes
- Tomar precauciones para evitar pillarse los dedos
- No desarmar o remodelar los brazos
- No montar el monitor antes de ensamblar el poste
- No ajustar el monitor antes de fijar el brazo
- Los tornillos para la pantalla NO están incluidos. Contactar con su proveedor del monitor
- Los tornillos para el ajuste a la pared NO están incluidos
- Algunos monitores tienen recesos y podrían requerir espaciadores o una placa VESA de 75mm

## MANTENIMIENTO E ISPECCION

- Asegurarse de que todos los tornillos estan apretados y ajustarlos de nuevo si fuera necesario. Limpiar con un paño húmedo. No utilizar solventes.

## ⚠ AVVERTENZA

Italiano

- Accertarsi che la scrivania, la superficie di lavoro, la parete o la tramezza siano adatte a sostenere il peso dei bracci e dei monitor.
- Non usare questo prodotto per scopi diversi da quelli per cui è stato progettato.
- Il peso del monitor non deve superare i 9kg per braccio.
- Tenere ben fermo il monitor quando si effettuano regolazioni.
- Fare attenzione a non pizzicarsi le dita.
- Non smontare o rimodellare i bracci.
- Non fissare il monitor prima di aver assemblato il braccio.
- Le viti per fissare il monitor NON vengono fornite in dotazione. Si prega di contattare il fornitore.
- Le viti per il montaggio a parete NON vengono fornite in dotazione.
- Alcuni monitor sono ad incasso e possono necessitare di distanziali o di una piastra VESA da 75mm.

## MANUTENZIONE E ISPEZIONE

- Controllare che tutte le viti siano ben serrate e, all'occorrenza, stringerle di tanto in tanto. Pulire con un panno umido. NON usare solventi.

## ⚠ 注意

日本語

- デスク / 作業台 / 壁 / 仕切りなどが、アームとモニターの重さに耐えられる事を確認して下さい。
- 本来の目的以外の目的で本製品を使わないで下さい。
- 各アームが支える重さは9kgを超えないようにして下さい。
- モニター角度調整中はモニターをしっかりと持って下さい。
- 指を挟まないように注意して下さい。
- 本製品を分解したり、組み立て直したりしないで下さい。
- アームを組み立てる前にモニターを設置しないで下さい。
- スクリーンを取り付けるねじは付属していませんので、モニターの販売元にお問い合わせ下さい。
- 壁に取り付けるためのねじは付属していません。
- 本製品取付部に凹みのあるモニターには、スペーサー、又は75mmのVESAプレートが必要な場合があります。

## メンテナンスと点検

- すべてのネジが締まっていることを確認し、必要に応じて調整して下さい。固く絞った布で水拭きして下さい。溶剤を使わないで下さい。

## ⚠ 注意

中文

- 请确保所有桌面/工作表面/隔墙适合承受手臂和荧光屏的重量
- 切勿利用这产品在设计功能范围之外
- 每手臂承受重量不得大于9公斤(19.8磅)
- 当调整时,请紧固荧光屏
- 为了避免手指被夹,请谨慎
- 切勿拆散或更改手臂
- 手臂还没完成组合之前,切勿安装荧光屏
- 安装荧光屏的螺栓没提供,请联系荧光屏的供应商
- 安装墙置托架的螺栓没提供
- 因某些荧光屏有凹面,需要垫片或者75毫米VESA片

## 维修和检查

- 请确保所有螺栓必须紧固,如需要,请随时调整.请使用湿布清洁,切勿使用溶剂



## Installation instructions for Flo dynamic monitor arm

### List of components

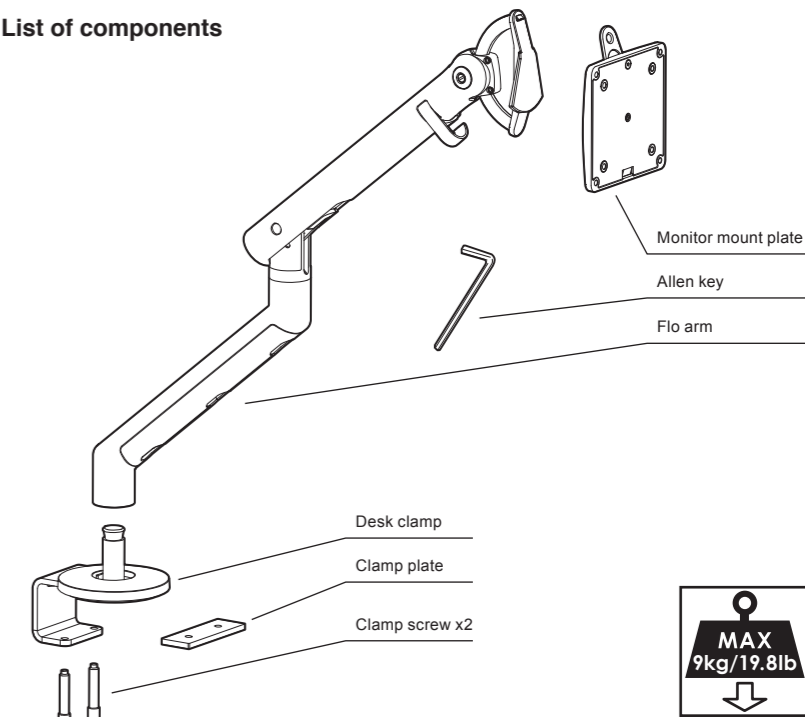

### Distributed by

[www.colebrookbossonsanders.com](http://www.colebrookbossonsanders.com)

## ⚠ WARNING

English

- Ensure desk / work surface / wall / partition is suitable to take the weight of the arm/s and monitors.
- Do not use this product for any purpose other than that for which it was designed.
- Supported weight must not exceed 9kg (19.8lb) per arm.
- Hold the monitor tightly when making adjustments.
- Care should be taken to avoid trapping fingers.
- Do not dismantle or remodel the arms.
- Do not attach the monitor before assembling arm.
- Screws for screen are NOT provided, please contact your monitor provider.
- Screws for wall mounting are NOT provided.
- Some monitors have recesses and may require spacers or a 75mm VESA plate.

## MAINTENANCE and INSPECTION

- Ensure all screws are tightened and occasionally adjust if needed. • Clean with a damp cloth, NO solvent.

## PATENT and REGISTRATION

- Flo is protected by international patents and design registration.

### Before you start

The Flo clamp base is equipped with a 180° stop system. If you require 360° rotation, reconfigure the clamp before fitting to the worksurface. See section 10

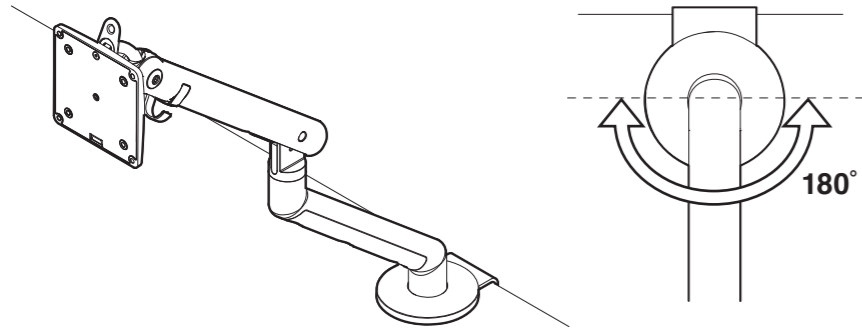

### Fit desk clamp to worksurface

1-1 Fit clamp screws into the clamp

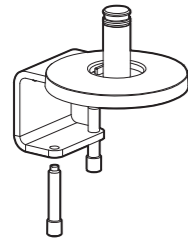

1-2 Fit clamp plate to tops of screws

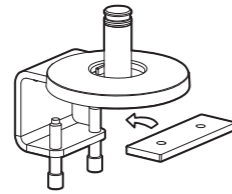

1-3 Fit clamp to worksurface

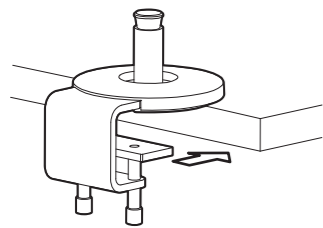

1-4 Tighten clamp screws

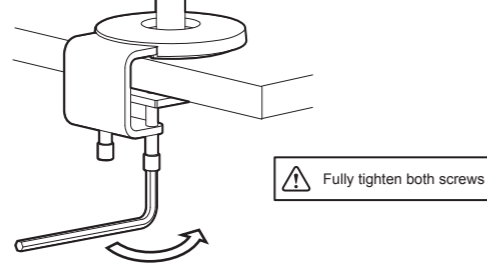

### Fit monitor arm to clamp

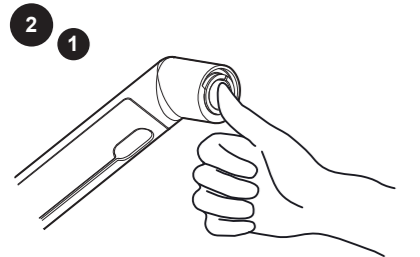

Be sure that plastic bush is pushed fully into monitor arm base

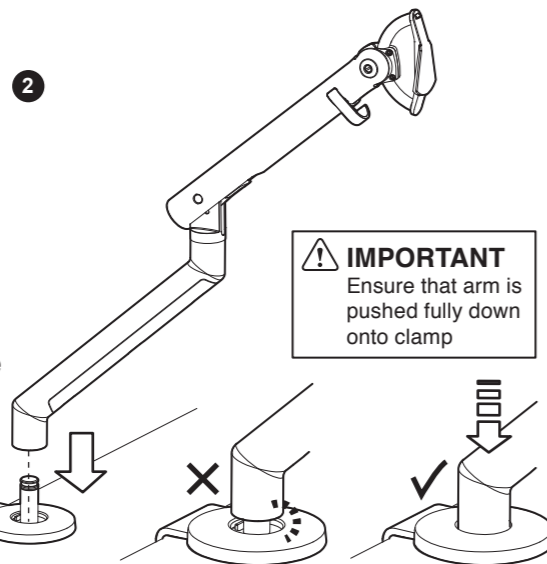

### Attach monitor mount plate to monitor

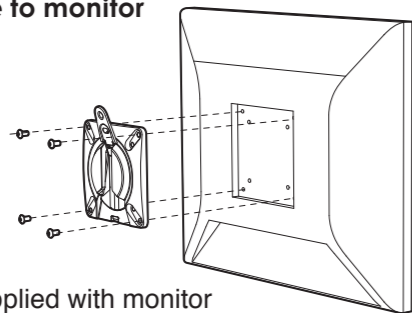
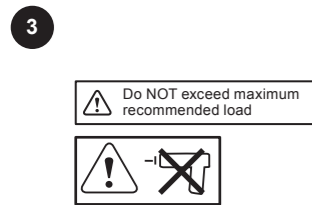

Use screws supplied with monitor

### Mount monitor to arm

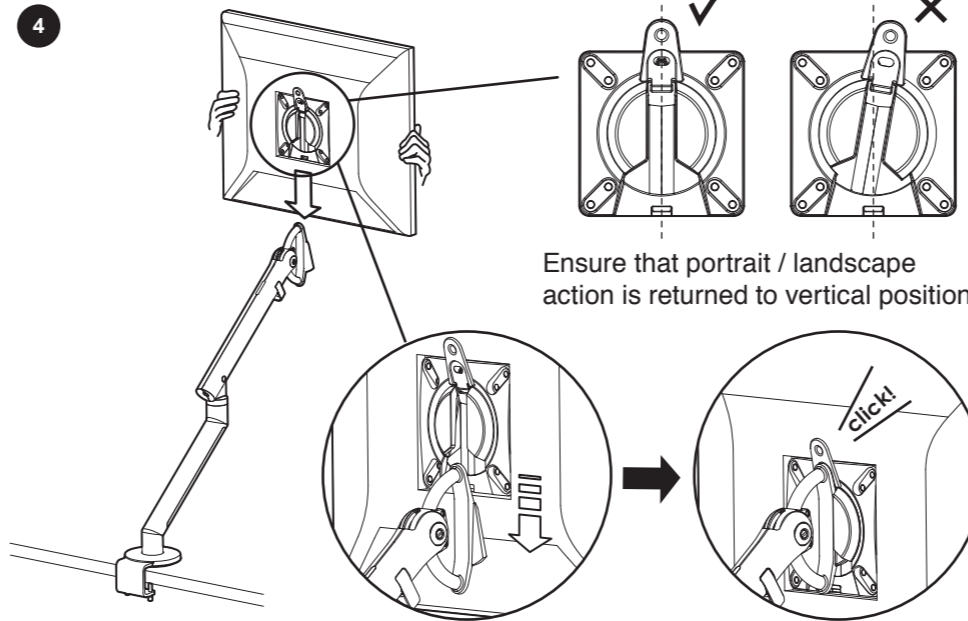

### To remove monitor

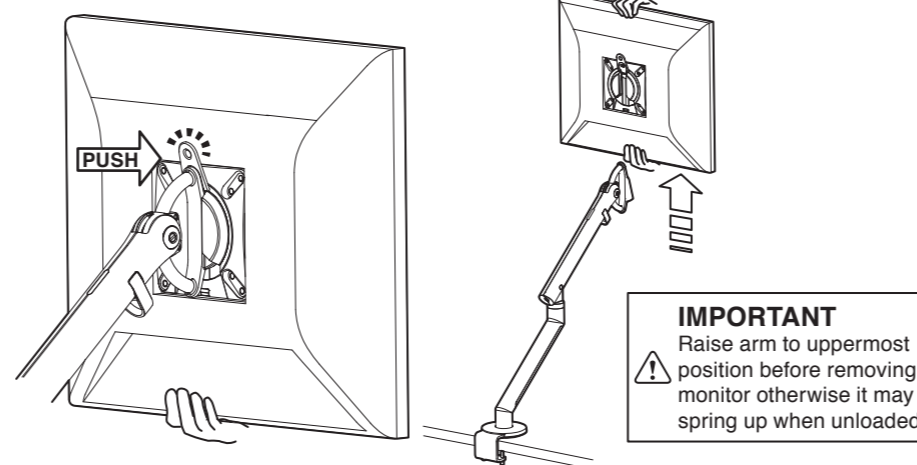

### Adjust arm to suit weight of monitor

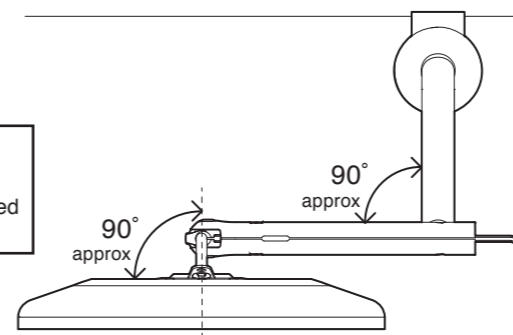
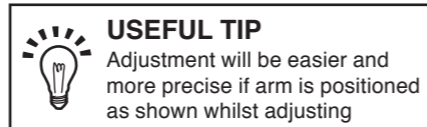
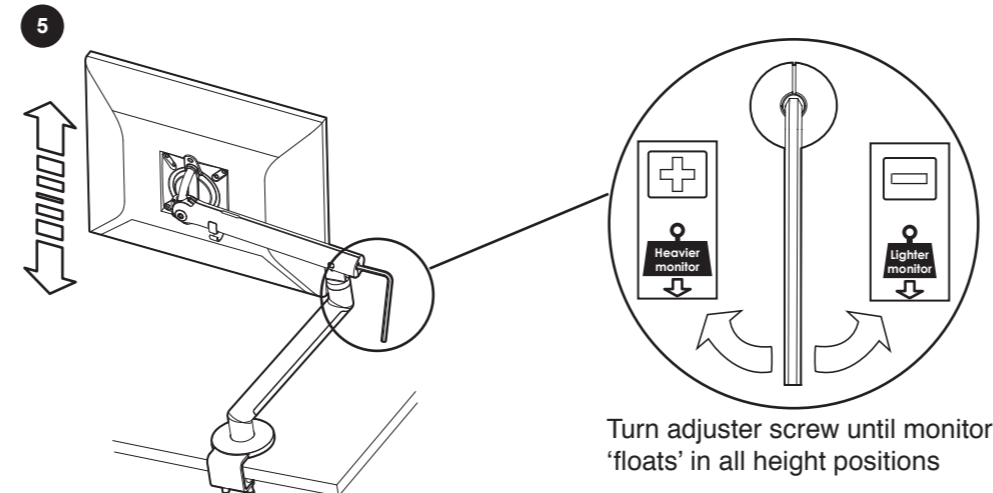

### Arm setting indicator

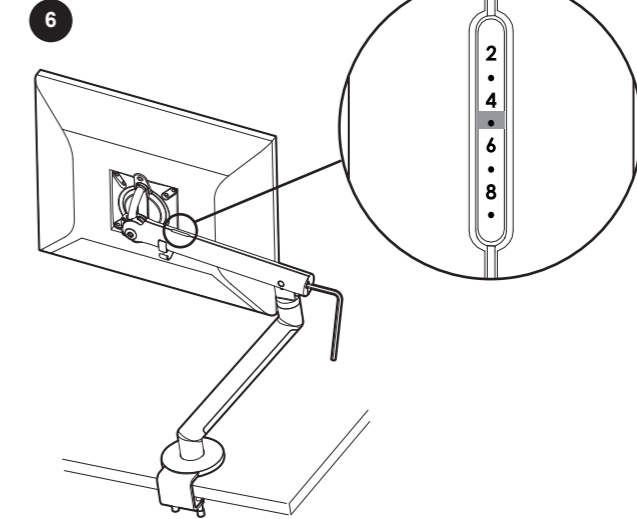

**USEFUL TIP**  
When installing similar monitors on a large quantity of arms you can save time by reading off the indicator setting of the first installed arm. This will give you a guide to the setting for the other arms. You can quickly 'dial in' to the same setting, then if necessary, fine tune the adjustment to balance the monitor

### Install monitor cables into cable management features

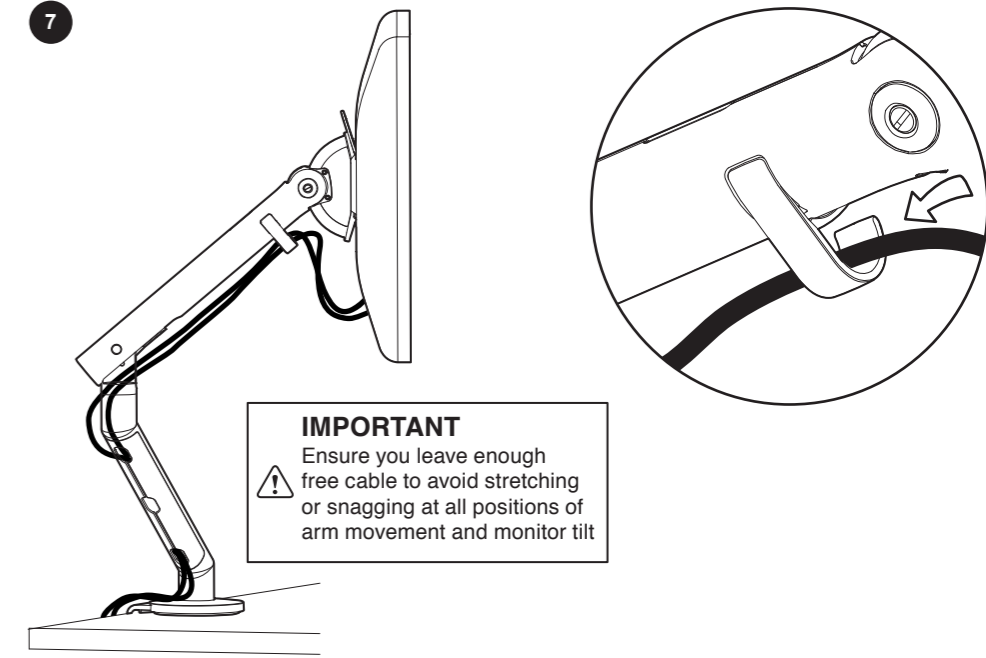

### Monitor tilt action

