

AVALL™



colebrook **bossonsaunders**

AVALL™

A new generation of screen supports to suit the modern environment...

AVALL is our multi-functional and multi-faceted large screen support system. Designed with flexibility and functionality at its core, AVALL can be used for a variety of purposes to combine practicality with exceptional design. If you're looking for a solution to your AV/VC needs, then see what AVALL can bring to your business.

To support the range of applications for which it was designed, AVALL can support different screen configurations (see top opposite page, *fig 1-4*)

AVALL can be supplied in the following versions...

Freestanding

(on feet or castors)

Wall mounted

(swing or static version)

avallstand.com



1. Single screen portrait



2. Single screen landscape



3. Dual screen portrait



4. Dual screen landscape

AVALL can be used for a wide range of applications, including:

Videoconferencing

Various camera mount options, screen configurations and secure codec facility make AVALL perfect for VC. AVALL can support codecs from all leading videoconferencing manufacturers.



Corporate presentations

AVALL can be used in any board, meeting, or training room and easily integrates IT equipment to support presentation material.



Digital signage

Screen size capability and security features make AVALL highly suitable for public spaces, and therefore digital signage.



Temporary and permanent signage

Freestanding and moveable options make AVALL perfect for a variety of signage requirements.



What makes AVALL different?

AVALL has a number of specially designed features that ensure ease of use, safety and security, and aesthetic quality.

AVALL is designed to be compatible with most AV/VC hardware suppliers and therefore can be used for videoconferencing, digital signage, and presentations. If your organisation needs flexibility in its stand usage requirements, AVALL provides it.

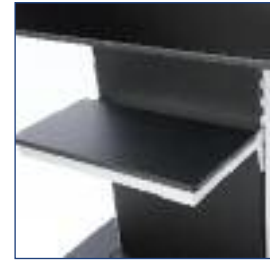

Adjustable shelf

Optional, height adjustable accessory shelf to support laptops, DVD players, or other technical equipment.



Adjustable camera mount

The camera mount can be placed in different locations to create an ergonomic VC/AV solution and find the most compatible set up for your space.



Safety

When holding up to 2 x 52" screens or a single 65" screen you need to be sure that the stand is safe, especially in public spaces. AVALL has been extensively tested for load support and stability. Concealed housing of equipment and cabling minimises the risk of user contact with the electrical installation and of damage to expensive equipment.



Connectivity

Whether the installation simply requires a basic power supply cord or a complex array of AV input/output connections, AVALL's modular connector panel system can be configured to suit any connectivity requirement.





Cooling function

Maintain optimum performance of IT equipment as specifically designed ventilated panels regulate temperature to prevent overheating. For higher density installations, cut-out details are provided for standard format cooling fans.



Lockable IT hardware

Ensure that IT hardware is locked away securely to prevent unauthorised tampering or theft. The simple but secure mechanism ensures safety for laptops; DVD players; codecs; and audio accessories. The ease of access for authorised users also allows easy diagnostics and reconfiguration. Cabling between equipment is tidily concealed from view within the unit.



Customisable furnishings and changing panels

AVALL can be customised with temporary panels for rented use or tailored branding for presentations/signage. It can also be integrated into a specific furnishing style through panelling on the front of the stand, perfect for the high end user.



Suitable for fixed or moveable installations

AVALL can be held in a permanent location or moved around on wheels in public spaces to deliver important information to groups/crowds of people.

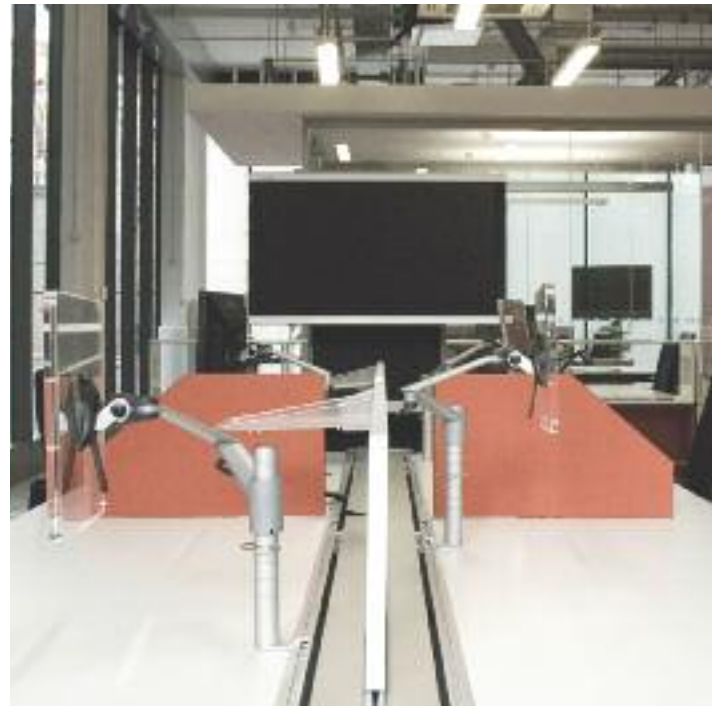

AVALL is suitable for most environments including:

- Airports and passenger terminals**
- Educational environments**
- Healthcare environments**
- Offices**
- Trading floors**
- Hotel and leisure environments**
- Public spaces**

AVALL system

AVALL technical specifications

Unit Height: 1600mm (63") with base

Unit Width: 628.5mm (24 3/4") wall mounted, 940mm (37") on base

Unit Depth: 283mm (11 1/8") wall mounted, 700mm (27 9/16") on base

Display Size: 30" to 65" (single) 30" to 52" (dual)

Maximum Load: 100kg (220lb)

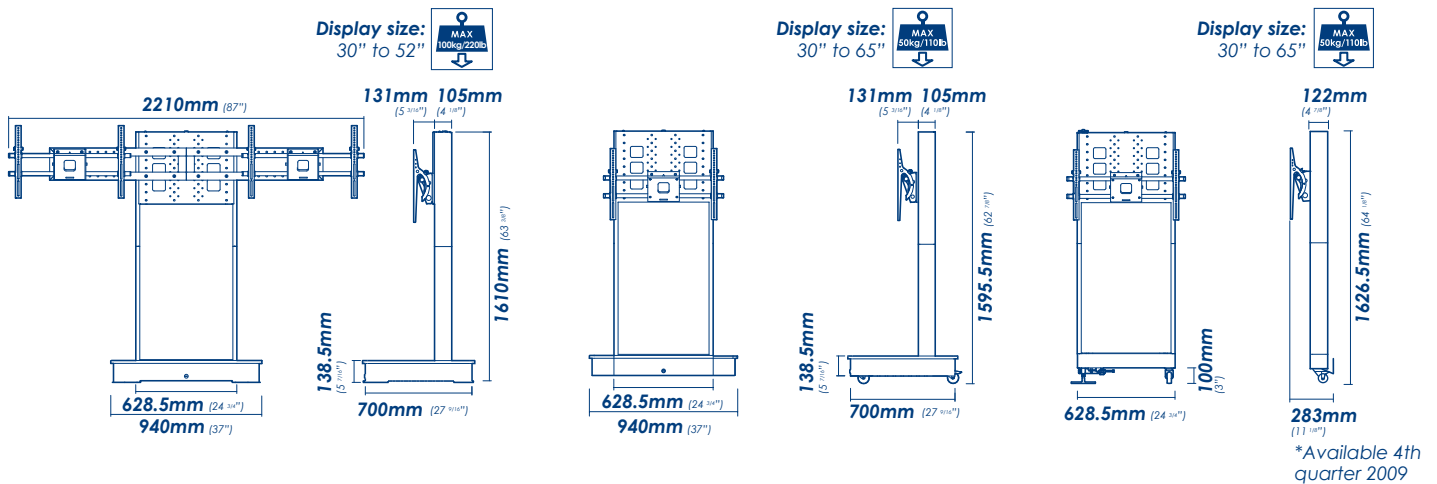
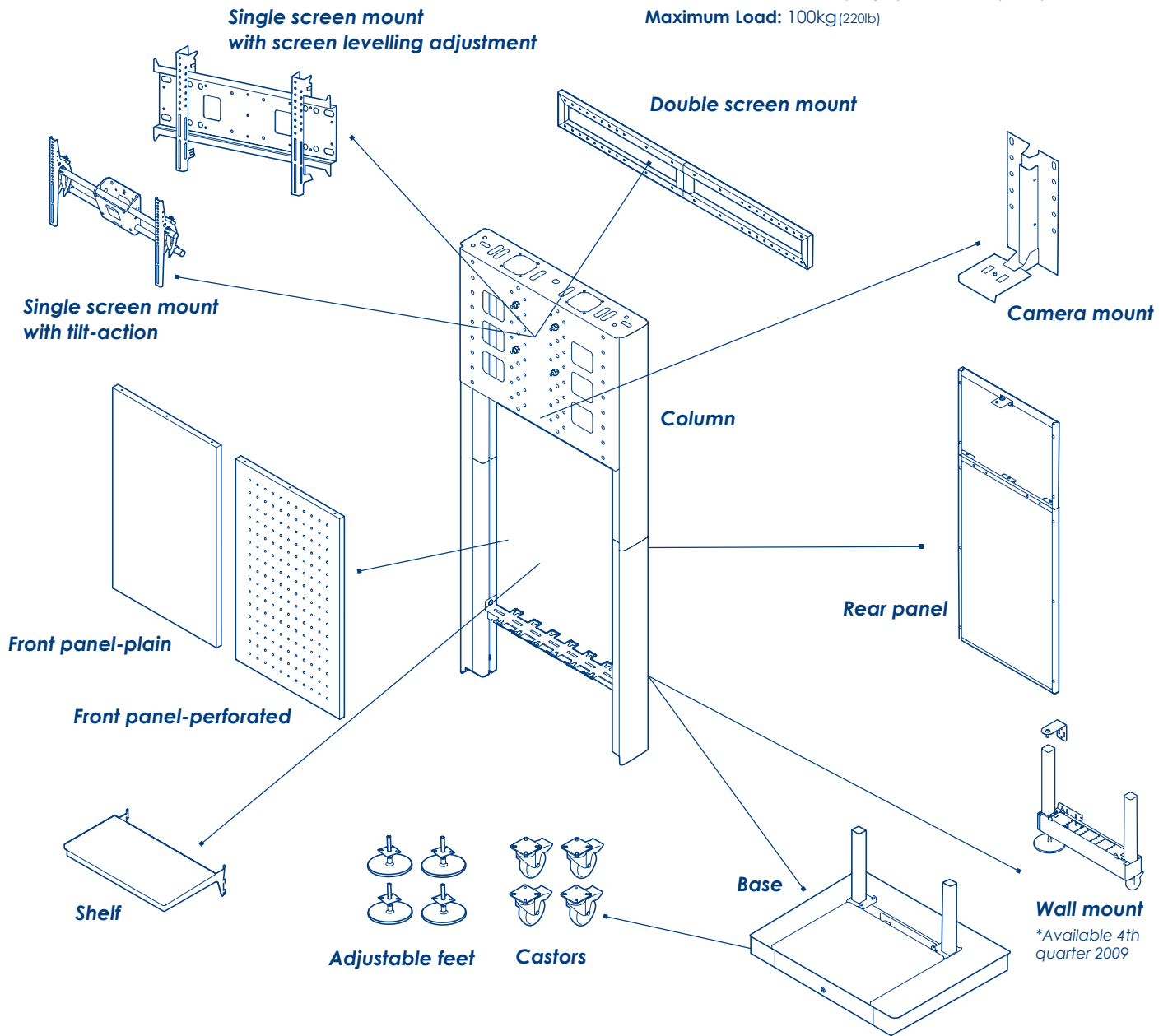

AVALL™



+44 (0)20 7940 4266
colebrookbossonsaunders.com
sales@cbsproducts.co.uk

 **colebrookbossonsaunders**

UK France Germany Benelux Russia
USA Australia Canada Japan UAE